

www.hawle.com



100% HAWLE 100%  
PROVEN QUALITY  
100% HAWLE 100%  
GEPRÜFTE QUALITÄT

www.hawle.com

100% HAWLE 100%  
PROVEN QUALITY  
100% HAWLE 100%  
GEPRÜFTE QUALITÄT

www.hawle.com

100% HAWLE 100%  
PROVEN QUALITY  
100% HAWLE 100%  
GEPRÜFTE QUALITÄT

www.hawle.com

100% HAWLE 100%  
PROVEN QUALITY  
100% HAWLE 100%  
GEPRÜFTE QUALITÄT

www.hawle.com

100% HAWLE 100%  
PROVEN QUALITY  
100% HAWLE 100%  
GEPRÜFTE QUALITÄT

www.hawle.com

100% HAWLE 100%  
PROVEN QUALITY  
100% HAWLE 100%  
GEPRÜFTE QUALITÄT

www.hawle.com

100% HAWLE 100%  
PROVEN QUALITY  
100% HAWLE 100%  
GEPRÜFTE QUALITÄT

www.hawle.com

100% HAWLE 100%  
PROVEN QUALITY  
100% HAWLE 100%  
GEPRÜFTE QUALITÄT



# HAWLE - *FITTINGS* for *CABLE CONDUITS*

easy - trouble-free - without screwed joints



HAWLE. **MADE FOR GENERATIONS.**



Art.-Nr.: ZA37000002



**E. Hawle Armaturenwerke GmbH**  
A-4840 Vöcklabruck  
Wagrainer Straße 13  
Tel.: +43 (0)7672 - 72576-0  
Fax.: +43 (0)7672 - 78464  
E-mail: hawle@hawle.at  
www.hawle.com

# THE "RIGHT" CONNECTION FOR CABLE CONDUITS



COUPLING FOR CABLE CONDUITS WITH PUSH-FIT SOCKET AT BOTH ENDS

## for PE cable conduits

Tension lock via proven interlocked grip rings

Fig. 1 COUPLING FOR CABLE CONDUITS WITH PUSH-FIT SOCKET AT BOTH ENDS

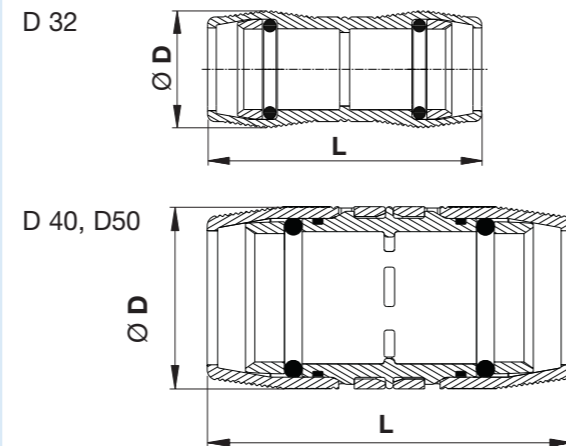

No. 6326

| Pipe-Ø mm | L   | D  | Weight / kg |
|-----------|-----|----|-------------|
| 32        | 110 | 48 | 0,10        |
| 40        | 124 | 61 | 0,22        |
| 50        | 138 | 70 | 0,27        |

## DESIGN FEATURES

- Easy to install - just push it on
- Easy to dismantle
- Tension lock acc. to DIN 16874
- For pipes, connections and installation acc. to DIN 16874, DIN 8074, DIN 8075 and DIN 16876
- Leak tightness acc. to EN 1610 0.5 bar
- For injection pressure up to 12 bar at max. for 2 hours
- Suitable for cable installation techniques "blowing in" and "pulling in"
- Short, slim design
- High-grade materials - body and grip ring of POM
- Sealings of proven elastomer

## TOOL AIDS FOR INSTALLATION AND DISMANTLING



### No. 6050 Pipe cutter

For smooth and rectangular cutting of pipes with little effort.

Type I: up to 1¼" or Ø 40 mm  
Type II: up to 2" or Ø 63 mm

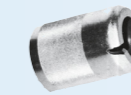

### No. 6000 Chamfering tool

For a trouble-free installation of the push-fit connection the pipe has to be chamfered.



### No. 6010 Extractors

For dismantling of push-fit fitting.



END FITTING FOR CABLE CONDUITS

## for PE cable conduits

Protection against dirt  
After removal of the cap (Fig. 2) a sealed cable conduit pressure tight to 0.5 bar is provided for Ø 10 mm to Ø 20 mm.

Fig. 2 END FITTING FOR CABLE CONDUITS

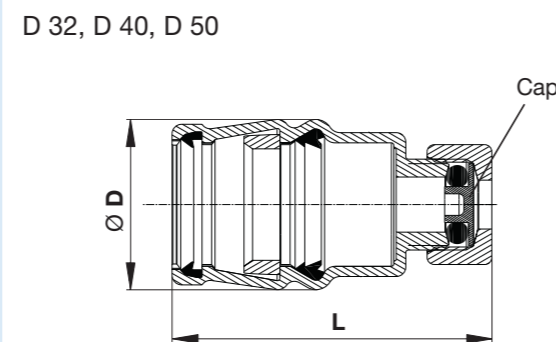

No. 6224

| Pipe-Ø mm | L       | D  | Weight / kg |
|-----------|---------|----|-------------|
| 32        | ca. 109 | 48 | 0,11        |
| 40        | ca. 119 | 58 | 0,15        |
| 50        | ca. 133 | 98 | 0,22        |

## INSTALLATION

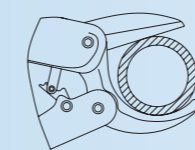

### 1. Cut pipe to length

Make sure that the pipe is cut to length accurately and at right angles.

### 2. Pease note! \*)

The sealing surface of the pipe must be smooth, clean and free from grooves! Observe mounting instructions!

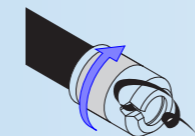

### 3. Chamfer the pipe

Push chamfering tool over pipe end. Some clockwise turns while pressing lightly - ready!

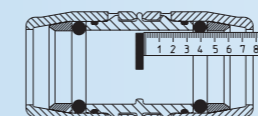

### 4. Establish the push-in depth

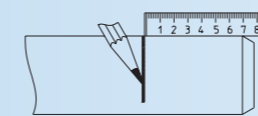

### 5. Check position of sealing rings and grip rings!

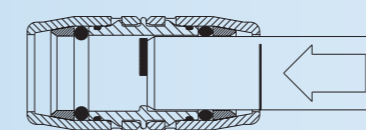

### 6. Push on fitting

Push on push-fit fitting completely.  
Check tensile strength by pulling at the pipe.

## DISMANTLING by means of extractors No. 6010

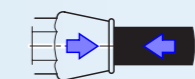

### 1. Relieve pipe.

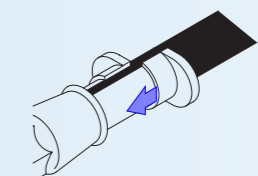

### 2. Push in extractors.

### 3. Remove pipe.

Exchange grip ring and O-ring!

\*) Condition of pipe:

The pipes shall have smooth outside surfaces depending on the respective production process, and they shall be free from blow holes and cavities. Sharp-edged grooves, burs and shrunken spots at connection points of the pipes are not acceptable. The appropriate condition of the pipes shall be especially observed when introducing the cable conduits and when using impact moles. The pipe ends shall be cut perpendicular to the pipe axis and they shall be free from burs. Clamping spots at the cable conduit produced by pulling in are not suitable for a clamped connection and have to be cut off.